

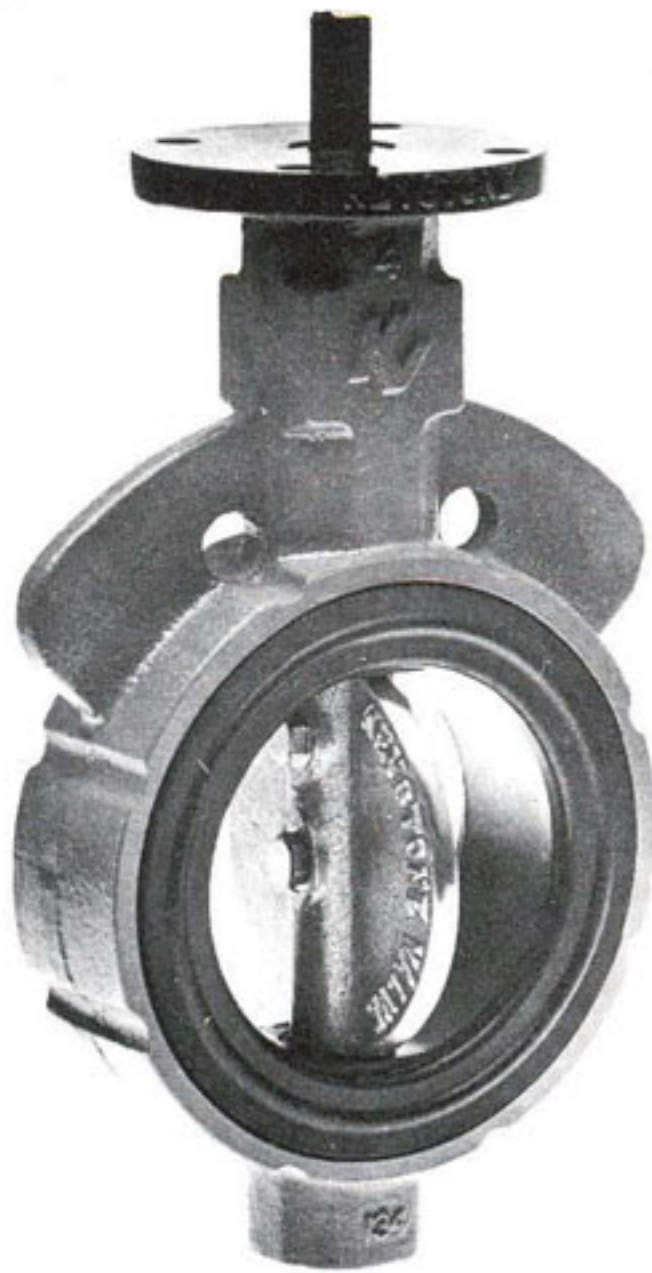

General Purpose Valve

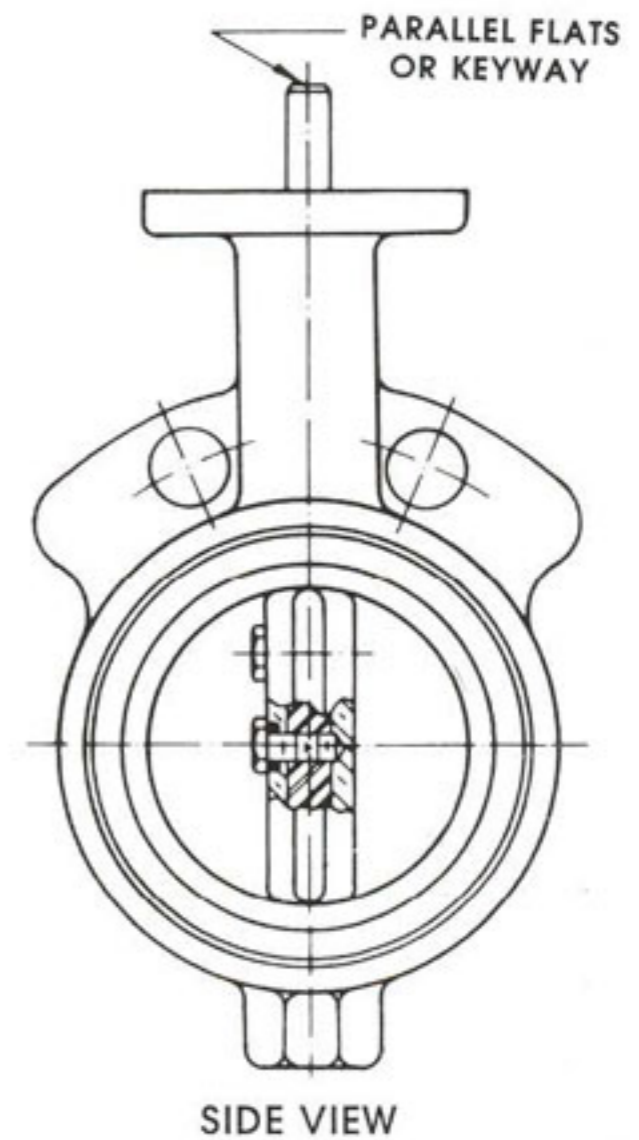

- TYPE** : General purpose wafer valve
- APPLICATIONS** : Liquids, gases, bulk handling etc.
- SIZE RANGE** : 50 to 500 mm
- PRESSURE RATING** : Vacuum to 10 kg/cm² tight shut-off
- TEMPERATURE RATING** : Minus 40° C to 120° C with EPDM seat.
Minus 18° C to 100° C with Buna N seat.
- STANDARD TRIMS (Others Available)** : Body = Cast Iron, Cast Steel, Stainless Steel
Disc = Ductile Iron, AL-Bronze, CF8M
Shaft = 304 S/S, 316 S/S, 410 S/S
Seat = EPDM, Buna N and VITON
- STANDARD FLANGING (Others Available)** : ANSI 150#, PN 10, BS 10 Table E

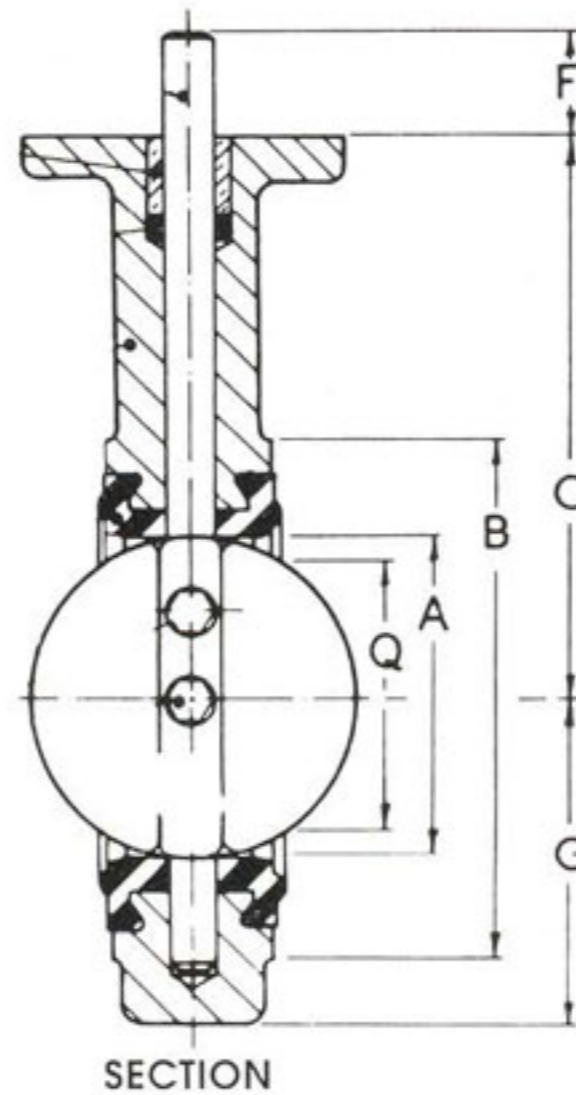
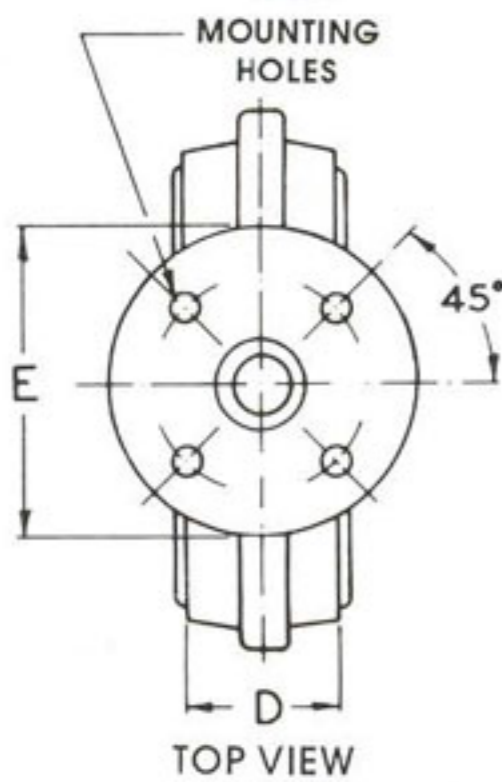

Valve Size mm	Mounting Code	SHAFT DIA. mm	NOMINAL DIMENSIONS										TOP FLANGE DETAILS			NOMINAL WEIGHT Kg.
			A	B	C	D	E	F	G	Q	(STEM CONN.)		PCD mm	No. Holes	Hole Dia. mm	
			mm	mm	mm	mm	mm	mm	mm	mm	mm	mm				
50	BAB	14.3	52	105	140	41	102	32	70	33	14.3 x 9.5		82.5	4	11	3
65	BAB	14.3	65	117	152	44	102	32	76	48	14.3 x 9.5		82.5	4	11	4
80	BAB	14.3	78	132	159	44	102	32	88	65	14.3 x 9.5		82.5	4	11	5
100	BAC	15.9	103	163	178	51	102	32	102	90	15.9 x 11.1		82.5	4	11	6
125	BAD	19	129	187	191	54	102	32	119	117	19 x 12.7		82.5	4	11	7.5
150	BAD	19	148	216	203	54	102	32	133	138	19 x 12.7		82.5	4	11	9
200	CAF	22.2	199	271	341	64	152	32	170	189	22.2 x 15.9		127	4	14	16.5
250	CAF	28.6	250	330	273	64	152	51	210	241	28.6	6.4 x 6.4	127	4	14	22
300	CAF	28.6	301	376	311	76	152	51	238	291	28.6	6.4 x 6.4	127	4	14	34
350	CAG	34.9	339	425	305	76	152	76	248	331	34.9	7.9 x 7.9	127	4	14	42
400	CAH	41.3	390	484	329	102	152	76	279	377	41.3	9.5 x 9.5	127	4	14	61
450	DAJ	47.6	441	546	368	108	203	108	314	428	47.6	12.7 x 9.5	165	4	21	88
500	DAJ	53.9	492	603	403	127	203	108	349	475	47.6	12.7 x 9.5	165	4	21	112

Q IS THE DIMENSION AT FACE OF VALVE FOR DISC CLEARANCE INTO PIPE OF FLANGE
WEIGHT DEPENDENT UPON MATERIALS USED.





Installation and Maintenance Instructions

PARTS DRAWING

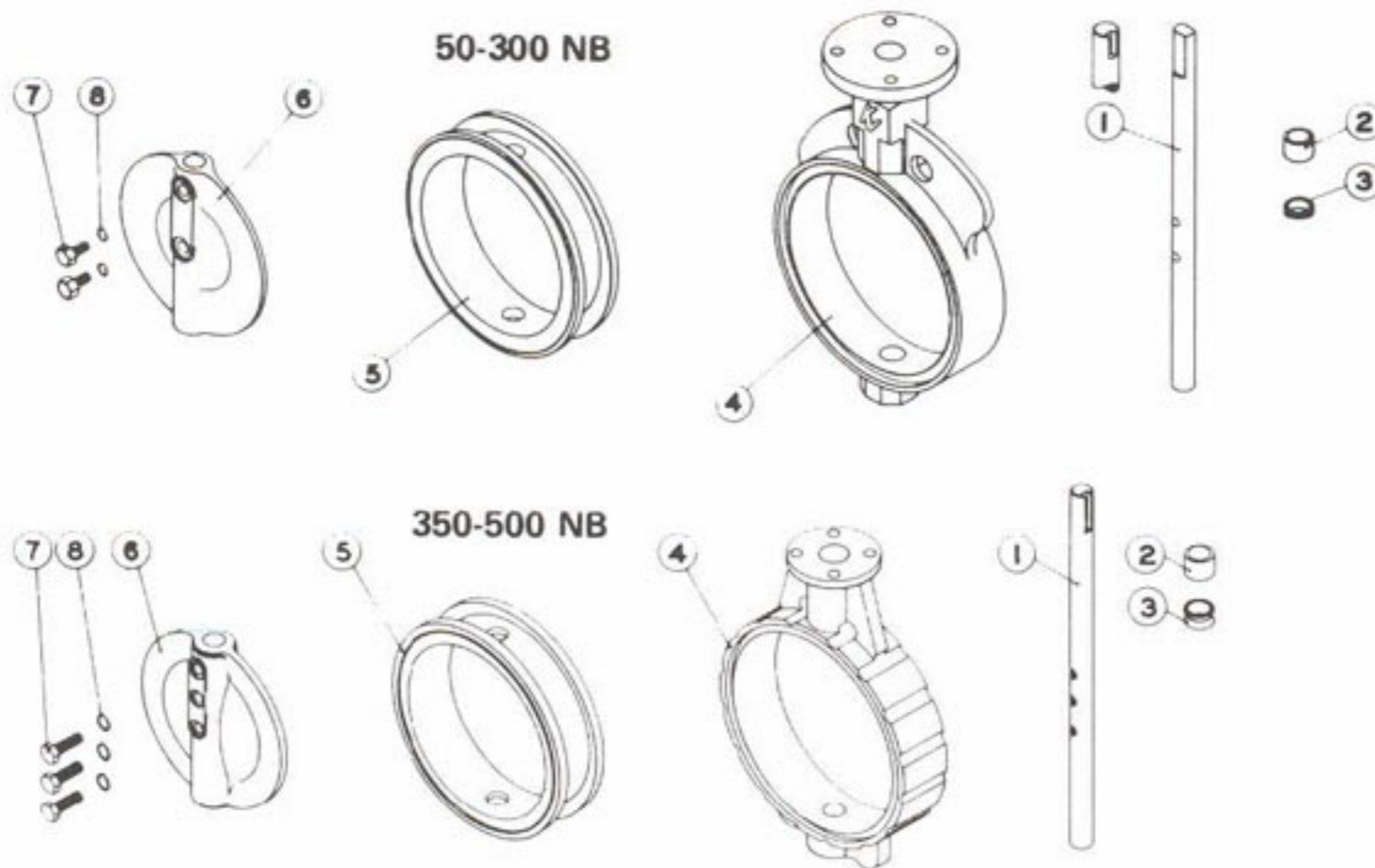

ITEM NO	NAME	NO. REQD
1	SHAFT	1
2	BUSHING	1
3	SHAFT SEAL	1
4	BODY	1
5	SEAT	1
6	DISC	1
7	DISC SCREWS	2
8	'O' RING	2

*3 OFF REQUIRED ON 350 TO 500 NB WHEN ORDERING STATE VALVE SIZE, TYPE, COMPONENT AND MATERIAL

FLANGE REQUIREMENTS: Keystone valves are suitable for installation between most international standard flange systems of PN. 10/ANSI. 150 rating (Refer valve data sheets for standard drillings provided.)

For vacuum high velocity, pressure surge and severe service duties, weld neck type flanges (flange I.D approximates valve bore) are recommended to ensure maximum valve performance.

Ensure pipe/flange I.D is greater than the open valve disc ('Q' dimension) particularly on cement or rubber lined, or heavy walled pipe. Do NOT weld near valve. Do NOT use flange gaskets or sealing compounds.

INSTALLATION: Keystone valves are bi-directional and will control flow in either direction of flow.

In most horizontal pipe installation it is recommended that the valve be installed with its shaft horizontal and the lower disc edge opening downstream, particularly on slurry or sedimentary duties.

NOTE: The valve disc position is in line with the key way or flats on the operator end of the valve shaft.

To protect disc edges during installation removal or storage of valves, ensure the disc is in the nearly closed position (about 5° open) and within the confines of the valve body, but NOT fully closed as incorrect seat compression may occur.

With suitable tooling spread the flanges clear of the valve and seat, insert valve, then flange bolts. Before fully cross tightening bolts check flange alignment and operate valve slowly to ensure disc clearance and seat compression is correct.

Maintenance: No routine maintenance or lubrication is required.

REPAIRS: Keystone valves are field repairable. If it is necessary to replace components the valve must be removed from the pipe.

Procedure: Partially close valve (5° open) Disconnect power supplies; remove operator on larger valves; remove sufficient flange bolts; spread flanges and remove valve.

Silicone base oils or grease may be used on all parts to facilitate disassembly, Do NOT use hydrocarbon based products with EPDM seats (green dot).

VALVE DISASSEMBLY : Open valve, remove the operator from the valve. Remove disc screws. Withdraw shaft, bushing and seal. Push disc edge-wise out of valve. (Protect edges.) Collapse seat and remove from the body.

VALVE ASSEMBLY: Collapse seat, align shaft holes and snap seat into body dovetails. Insert shaft seal then bushing. Insert shaft seal then bushing. Insert shaft until it slightly protrudes into bore. With screw holes toward valve top, place top disc hole over shaft and roll disc into position. Smoothly push shaft downwards through disc and into lower body. Align shaft disc-screw holes (counterbored side towards disc holes.) Insert disc screws with 'O' ring seals and tighten to 16NM.

